

StormPit®

SURFACE WATER SUMPS

Built for Compliance.

StormPit Type Two



THE APD StormPit RANGE HAS BEEN DESIGNED TO MAKE YOUR JOB EASIER!

Why use heavy, difficult concrete sumps when you can use a New Zealand building code compliant APD Type Two sump and make your job easier?

**LIGHTER!
EASIER!
FASTER!**

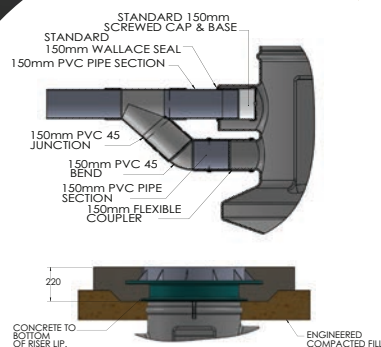

FEATURES

- Lightweight, sump and riser are only 45kg - an easy two person lift.
- Moulded in lifting eyes if required.
- Adjustable in height from 1270mm – 1520mm from the base of the unit to FGL.
- Will fit a range of class D 600mm opening round grates.
- Ability to easily install 150mm UPVC syphon with access cap.
- Easy cutting with hole saw and use of 150mm rubber seals.
- 1 x 250mm OD spigot, 2 x 160mm OD (150mm UPVC) spigots and 2 flat panels for multiple inlet or outlet locations.
- 250mm of height adjustment.
- Anti-flotation ring, no additional concrete required.
- Easy height identification marks for cutting and drilling.
- Made in NZ of durable recyclable HDPE.
- Manufactured from water tank grade PE material suitable for below ground installations.

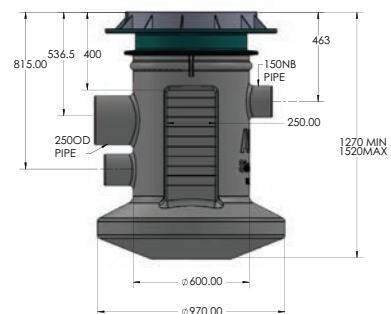

For more information contact your APD account manager or call (09) 263 7741

www.apd.co.nz

APD

IDEAL TANK & SYSTEM SOLUTIONS

May 2021

StormPit[®]

SURFACE WATER SUMPS

Built for Compliance.

StormPit Bubble Up



The APD StormPit Bubble Up chamber is designed to meet all the NZBC requirements, making your job faster and easier!

**EASIER!
FASTER!**

APD's StormPit range offers more than just compliance to NZBC E1 – we have designed additional features to benefit the installer onsite and ensure long-term, trouble-free use.

ADDITIONAL FEATURES

- Adjustable in overall height from 835mm – 1010mm.
- Moulded garden lid with fixings.
- 175mm of height adjustment.
- 2 x flat panels for easy installation of pipe and seals to the required height.
- 2 x 100mm wallace seals provided.
- Anti-flotation ring, no additional concrete required.
- Easy height identification marks for cutting and drilling.
- Made in NZ of durable recyclable HDPE.
- Manufactured from water tank grade PE material suitable for below ground installations.

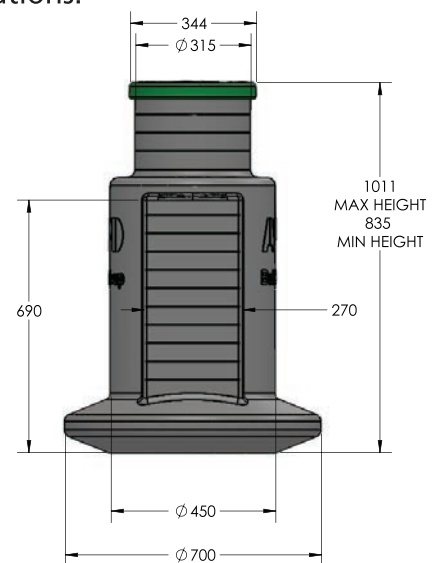
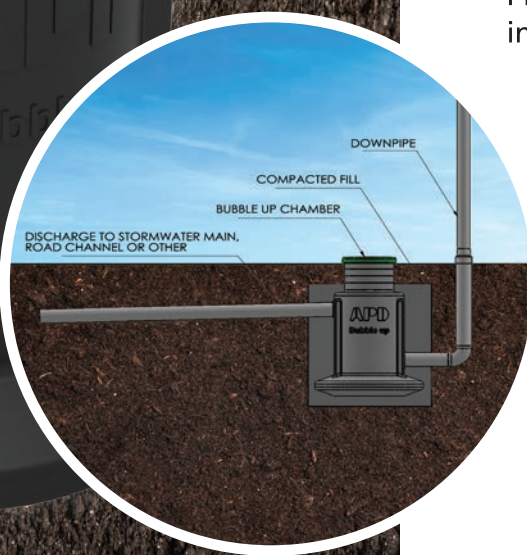

For more information contact your APD account manager or call (09) 263 7741

www.apd.co.nz

APD

IDEAL TANK & SYSTEM SOLUTIONS

May 2021