



Built for Compliance.

StormPit Type One



THE APD STORMPIT RANGE HAS IT ALL PLUS MORE!

Don't be fooled by non-compliant sumps and ensure you are complying to 'NZ Building Code E1 Surface Water' by installing the APD StormPit Type One sump today.

**EASIER!
FASTER!
IMPROVED!**



NZBC E1 TYPE ONE COMPLIANT SUMPS ARE REQUIRED TO HAVE

- 300mm opening.
- Maximum 1000mm height.
- 375mm diameter.
- Removable access cap for cleaning.
- A submerged or trapped outlet.
- 300mm minimum at base for silt settlement.
- Minimum 90mm outlet pipe.

APD's StormPit range offers more than just compliance to NZBC E1, we have designed additional features to benefit the installer onsite and ensure the long-term, trouble-free use.

ADDITIONAL FEATURES

- 5 tonne rated ductile iron grate fits into the main body for shallow depth installations.
- Adjustable in height from 171mm – 445mm from top of outlet pipe to finished ground level.
- 274mm of height adjustment.
- 3 x Moulded inlet connections sized for 100mm PVC.
- Full 100mm sized outlet with oversized trap for greater flow.
- Anti-flotation ring.
- No threads that can bind up with gravels and fines.
- Easy to remove access cap.

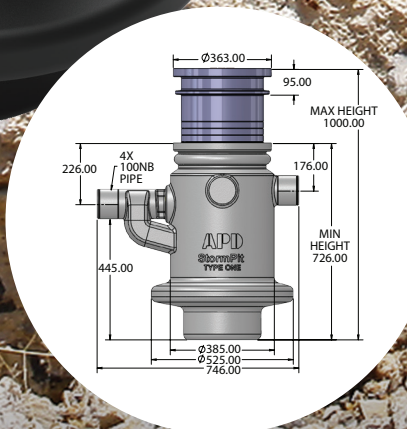

For more information contact your APD account manager or call (09) 263 7741

www.apd.co.nz

May 2021



IDEAL TANK & SYSTEM SOLUTIONS

StormPit[®]

SURFACE WATER SUMPS

Built for Compliance.

StormPit 250



If larger sumps need to meet NZBC E1 then why not make sure your smaller sumps meet the same requirements.



LIKE ITS BIG
BROTHER, OUR
250MM VERSION IS
EASIER!
FASTER!
IMPROVED!

ADDITIONAL FEATURES

- 1 tonne rated ductile iron grate fits into the main body for shallow depth installations.
- Adjustable in height from 132mm – 392mm from top of outlet pipe to finished ground level.
- 260mm of height adjustment.
- 1 x Moulded inlet connection sized for 100mm PVC.
- Full 100mm sized outlet with oversized trap for greater flow.
- Anti-flotation ring.
- No threads that can bind up with gravels and fines.
- Easy to remove access cap.

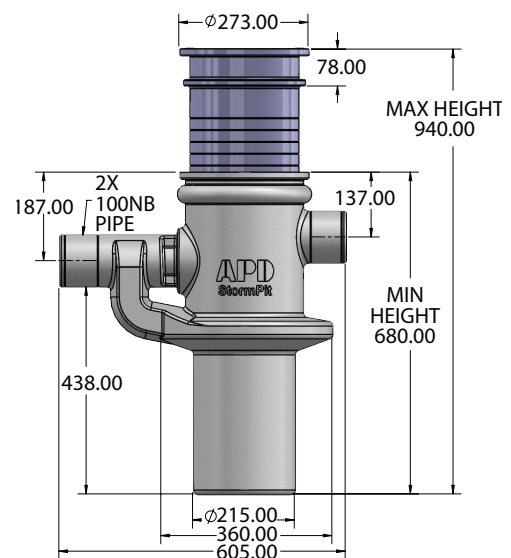

For more information contact
your APD account manager
or call (09) 263 7741

www.apd.co.nz

May 2021

APD

IDEAL TANK & SYSTEM SOLUTIONS