



Doing Good From The Ground Up



The Easy, Complete System.

# RainWorx<sup>®</sup> Owner's & Installation Manual



For more information call 0800 263 774  
[www.apd.co.nz](http://www.apd.co.nz)



Doing Good From The Ground Up

Congratulations on the purchase of an APD RainWorx® Rain Harvesting System.

For your convenience all our RainWorx® wall mounted systems come pre-assembled and fully leak tested prior to despatch. This provides an easy plug and play installation process that ensures you have a dependable solution for your rainwater harvesting needs.

Please familiarise yourself with this information before beginning installation.

**Caution:** All plumbing and electrical work during installation should be carried out and tested by licenced trades people.

**Servicing:** All servicing of the RainWorx® system should be carried out by qualified technicians.

If problems or questions arise during installation, please call our friendly customer service team on **09 263 7741**.

## Contents

### Installation

- Part 1: Pre-Plumbing **3**
- Part 2: Installing Pump into APD StormLite® Underground Tank **4**
- Part 3: Fit Pre-assembled Cabinet **5-6**
- Part 4: Switching On **7**

### Pump Setups

- RainWorx® Underground Tank with Submersible Pump **8**
- RainWorx® Underground Tank with Above Ground Pump **8**
- RainWorx® Under Slab Tank with Above Ground Pump **9**
- RainWorx® Above Ground Tank with Submersible Pump **10**
- RainWorx® Above Ground Tank with Above Ground Pump **10**
- RainWorx® Underground Tank with Submersible Pump Multistage Use **11**
- RainWorx® Underground Tank with Above Ground Pump Multistage Use **11**
- RainWorx® Underground Tank with Submersible Pump Garden Use Only **12**
- RainWorx® Above Ground Tank with Above Ground Pump Garden Use Only **12**

### Troubleshooting **13-14**

### Maintenance Instructions **14**

### Warranties and Assurances **15**

### Inspection Record **16**

## Installation - Part 1: Pre-plumbing

### APD RainWorx® Universal Template

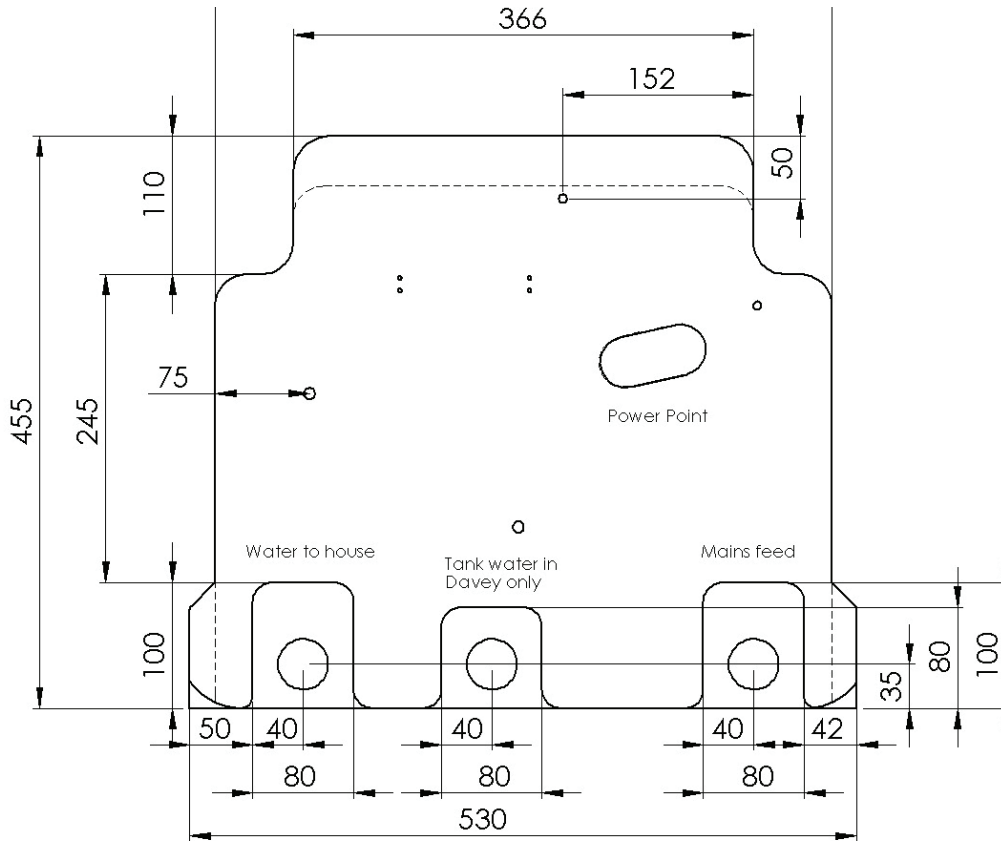

\*\* Screw locations should be kept within the dotted area above when fixing to wall.

- Use templates above to identify where to position plumbing connections for mains water in, water out to house and power point.
- Ensure the positioning of the cabinet is high enough from the ground to allow access to all connections for installation and servicing. The power point connection must be at least 400mm above finished ground level.
- Ensure all penetrations to the exterior of the house are in accordance with the building code.
- Direct power and water supply within the property to meet the cabinet holes.

**Note - a template of the RainWorx® backing board is available from APD Limited. This is designed to help guide you, when locating the plumbing and electrical connections, to match the RainWorx® control panel.**

## Installation - Part 2: Installing Pump Into APD StormLite® Underground Tank That Has Been Pre-fitted With Internal Pipework & Pump Platform.

1. Remove the tank lid to gain access to the inside of the tank chamber.
2. Undo the union fitting shown in the picture below and remove the hose with non-return valve from the tank. Be careful not to lose the washer inside the union fitting.
3. Connect the non-return valve at the base of the hose to the pump outlet.
4. Using the rope provided, lower the pump down into the tank so it sits correctly inside the pump platform.
5. Re-connect the hose to the union fitting inside the tank.
6. Locate the plug on the end of the pump's power cable and remove it or cut it off.

**\*\*Warning – do not cut off plug if it is connected to power\*\***

7. Locate the cable gland next to the union fitting on the inside of the tank and pull the pump cable through from the inside to the outside of the tank. You may need to dig out some soil/ backfill around the riser to gain access to the fittings.  
Note – pump cable may need to be extended if the distance between the tank and RainWorx® cabinet is longer than the cable. Standard pump cables are generally 10m long. Some pumps have 10m, 15m and 20m cable options available. If you need a longer cable, please enquire at APD.
8. Pull through any slack from the power cable and tighten cable gland.
9. Check the float switch cable on the pump is not obstructed and can move freely.
10. Dig required trench according to building code standards, between tank and RainWorx® cabinet location, to allow for power cable and water pipe to be run.
11. Connect water pipe (25mm ID minimum required) to 25mm tank fitting and run the pipe through the trench to the RainWorx® cabinet location. Bring power cable through to the same location and fit a new plug. Ensure the power cable is protected in accordance with the building code.
12. Backfill trench.

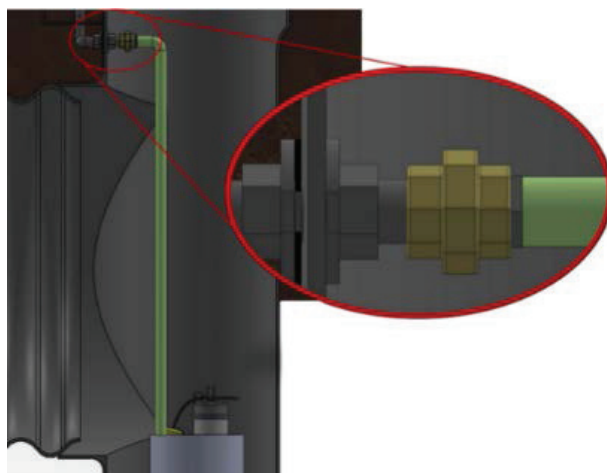

## Installation - Part 3: Fit Pre-assembled Cabinet

### Davey Rainbank Version

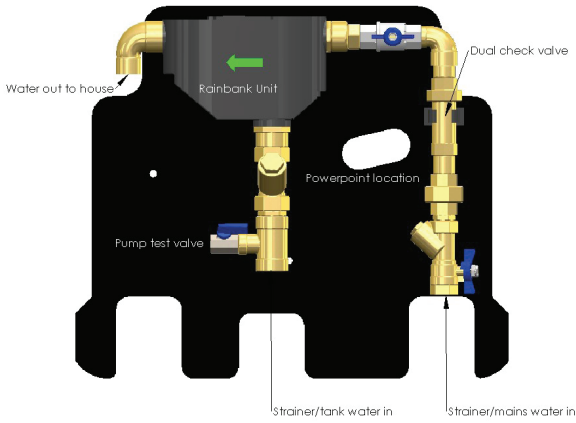

### Whites Rainsaver Version

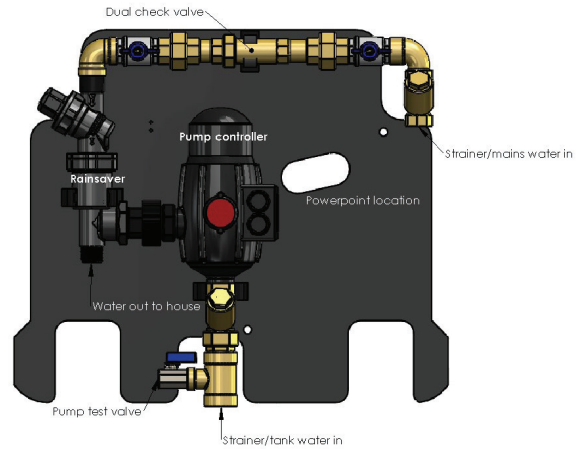

### Retrofit Version

Ideal for use with pumps (submersible or surface mounted) with in-built/internal pump controllers.

- Can be used for multi-home developments when one main pump is used to supply all the homes in a development with water reuse.
- Can be installed across multiple houses/units, when sharing a single multi-stage (variable drive) pump set up.

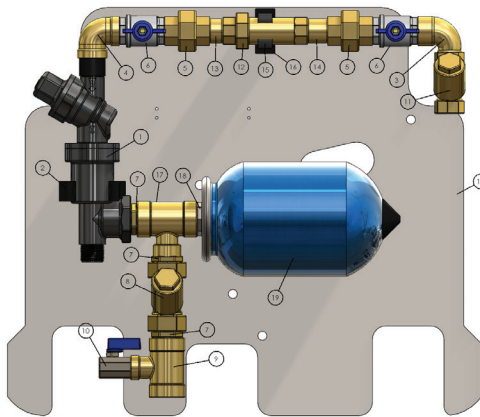

ITEM NO.	PART NUMBER	QTY.
1	1300021 and 1300038 (Rainsaver Configuration)	1
2	1200198 (Clip 40 NB)	1
3	1200008 (Crax to female elbow 20mm)	1
4	1200010 (Elbow female brass 20mm)	1
5	1200012 (Union female 20mm)	2
6	1200013 (Ball valve MIM nickel plated)	2
7	1200558 (Nipple brass hexagon 25mm)	3
8	1200561 (Inline Y strainer)	1
9	1200562 (Female reducing TEE Brass)	2
10	1200563 (Ballcock valve brass short handle)	1
11	1200568 (Inline Y strainer)	1
12	Dual check valve (1200940)	1
13	Barrel Nipple 20x45 (1200941)	1
14	Barrel Nipple 20x40 (1200942)	1
15	20NB pipe clip (1200195)	1
16	Spacer	1
17	Backing board	1
18	Pressure tank connector	1
19	Pressure tank	1

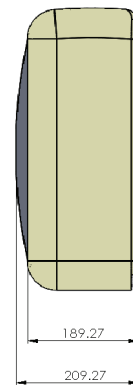
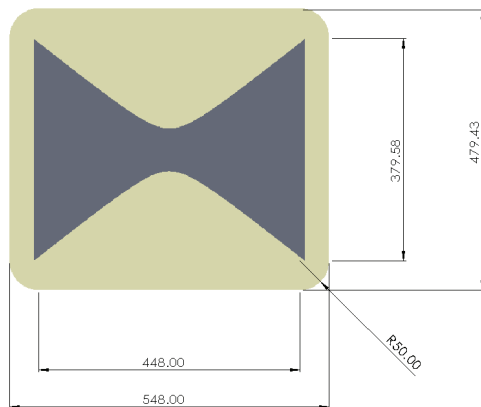



Doing Good From The Ground Up

### Installation - Part 3: Fit Pre-assembled Cabinet Continued

1. Separate the backing board assembly from the RainWorx® cover.
2. Position the backing board on the wall to ensure it lines up with the plumbing and electrical connections.
3. Screw the backing board to the wall using SS M6 or at least 10g screws suitable for timber or concrete. Position the screws in the middle of the backing board to keep the edges of the backing board from being pulled out of shape, as this can cause issues when sliding the cover on and off. Refer to template drawing in Part 1.
4. Connect all plumbing connections as per the diagrams above:
  - Mains water feed in. A pressure limiting valve must be installed prior to RainWorx® connection.
  - Water from tank to RainWorx®, within 10m 25mm ID, 10m – 20m 32mm ID, over 20m 40mm ID pipe required to ensure reasonable flow rates.
  - Water to house and internal fixtures must be minimum 17.6mm ID pipe

Nom. Outside Diameter	Mean Bore
18mm	12.5mm
22mm	17.6mm

5. Have an electrician install an outdoor rated power point in the location on the backing board.
6. Plug the power lead from pump to the Whites Pump Controller or Davey Rainbank.
7. Plug the power lead from the Whites Pump Controller or Davey Rainbank into the power point the electrician has installed.



Doing Good From The Ground Up

## Installation - Part 4: Switching On

1. Turn on mains water supply to house.
2. Ensure both isolation valves on either side of the double check valve are in the open position.
3. Switch the power point to the on position.
4. Check the controller is working correctly:
  - Whites Pump Controller version: Press pump reset to start pump, check there is no failure light.
  - Davey Rainbank version: Check status indicator, press manual override to check pump is running.
5. Check the pump is operational:
  - Open the pump test valve to check if water pressure is present. If not press Pump Reset (Whites) or Manual Override (Davey).

If there is no water pressure coming through or there is a failure light, please refer to the troubleshooting guide.

6. If everything is in working order then replace the cabinet cover by sliding from top down.

## Pump Setups

### RainWorx® underground tank with submersible pump

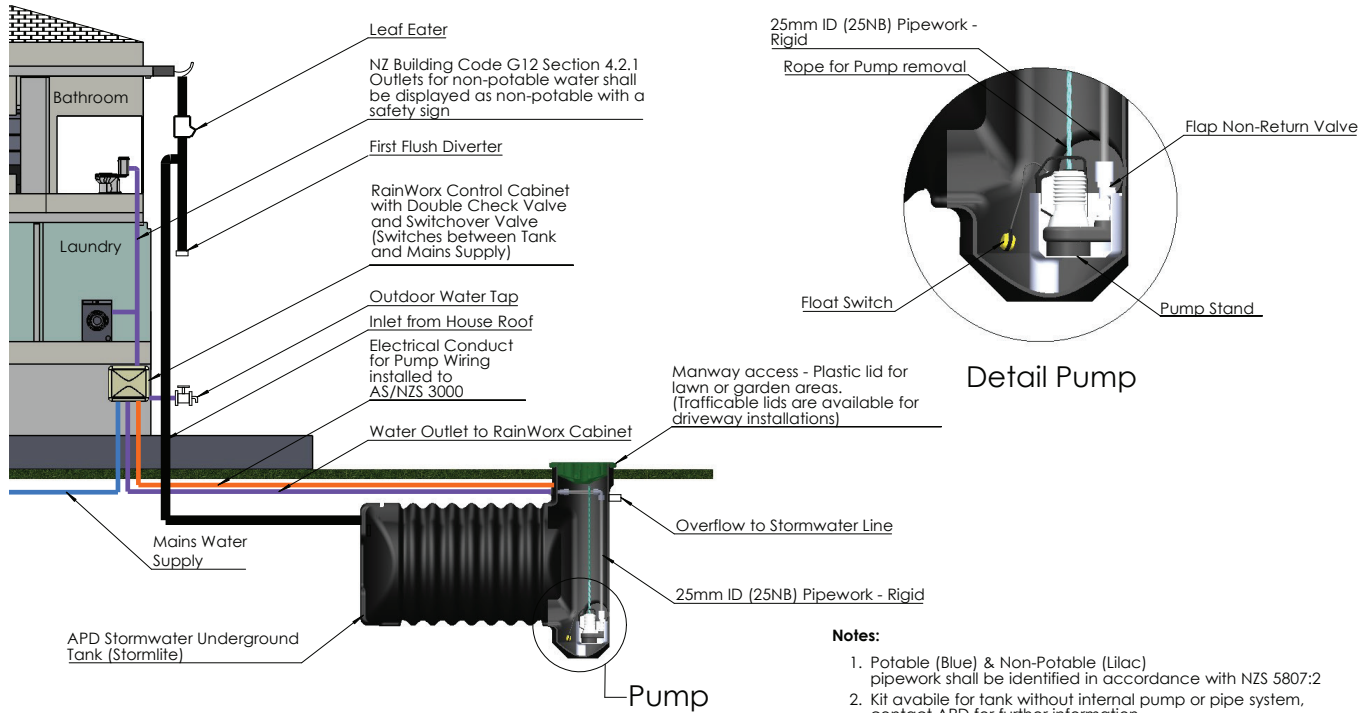

## Pump Setups

### RainWorx® underground tank with above ground pump

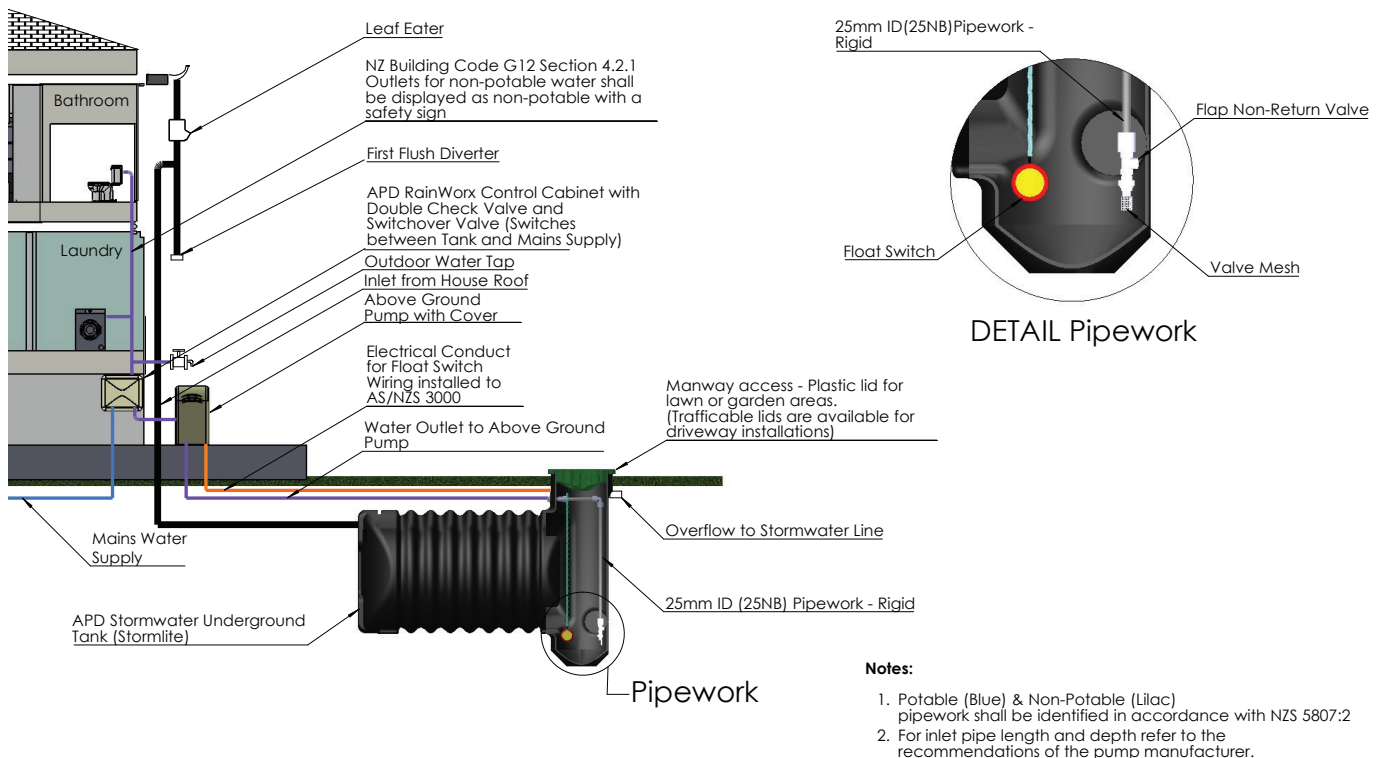

## Pump Setups

### RainWorx® under slab tank with above ground pump

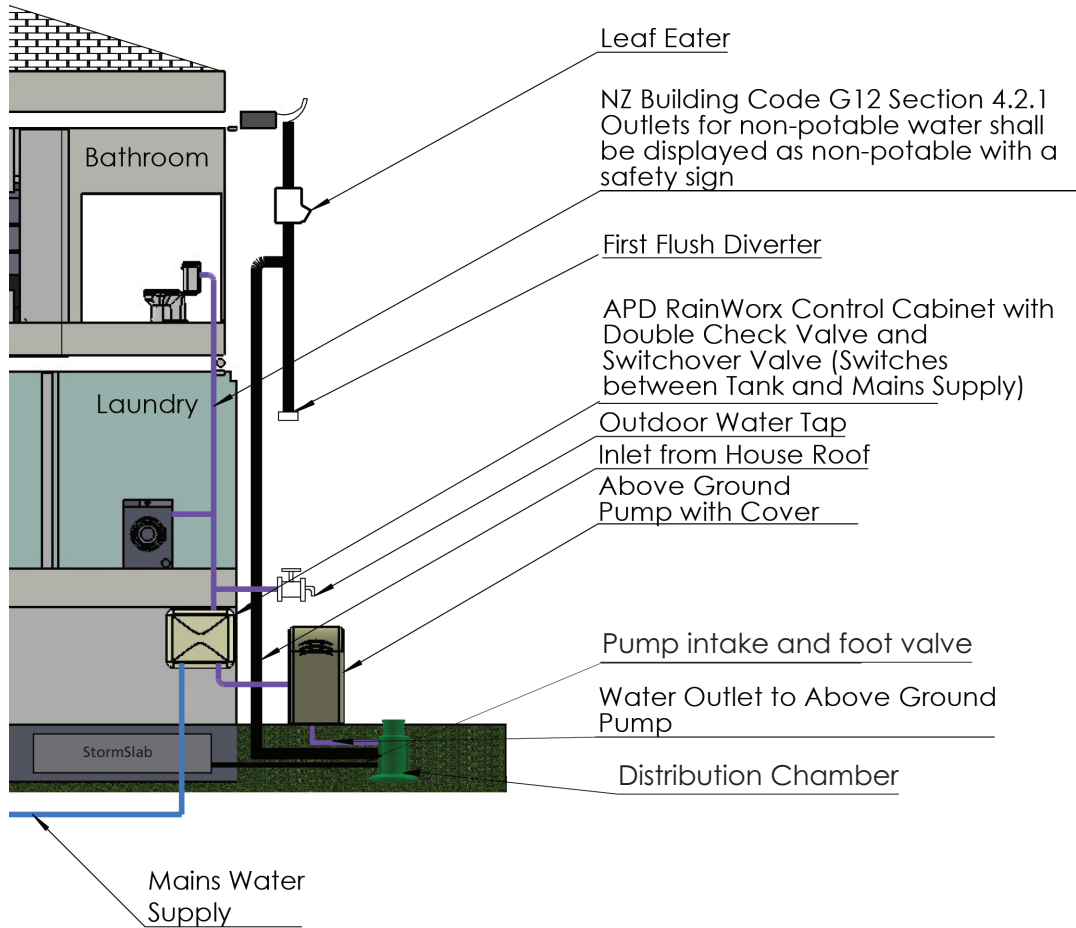

## Pump Setups

### RainWorx® above ground tank with submersible pump

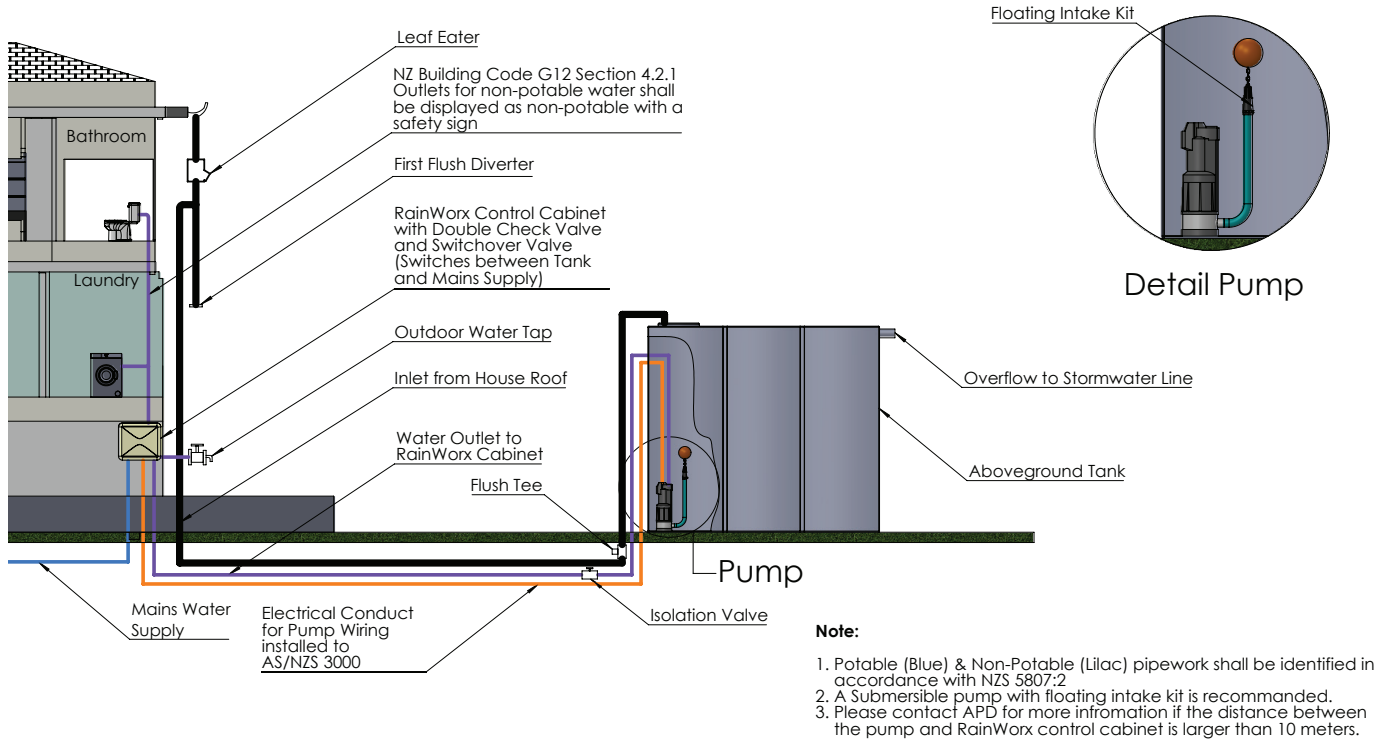

## Pump Setups

### RainWorx® above ground tank with above ground pump

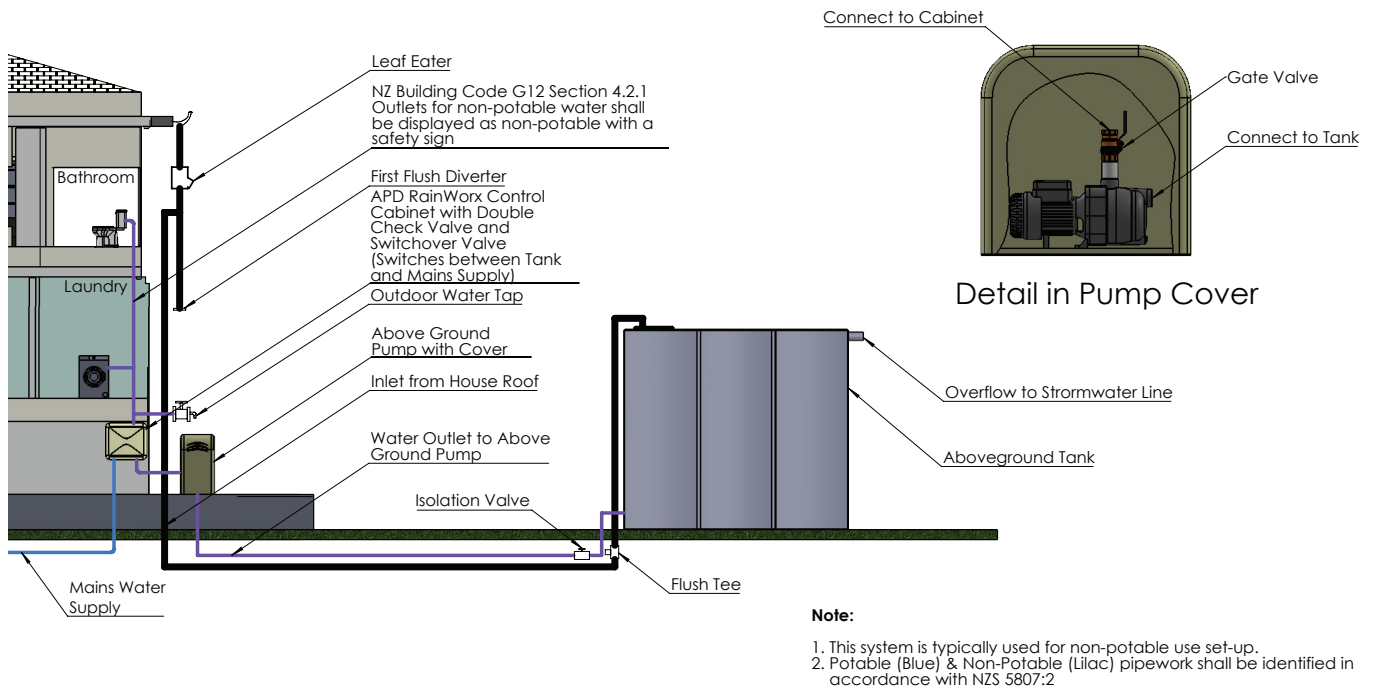

## Pump Setups

### RainWorx® underground tank with submersible pump multistage use (Variable Drive)

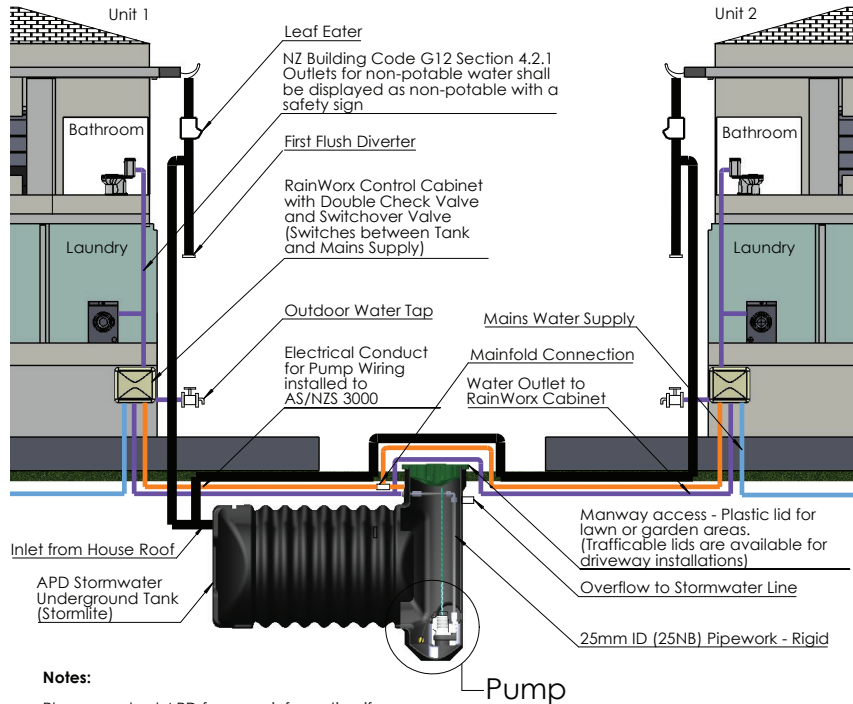

**Notes:**

Please contact APD for more information if more than two units/houses to be connected

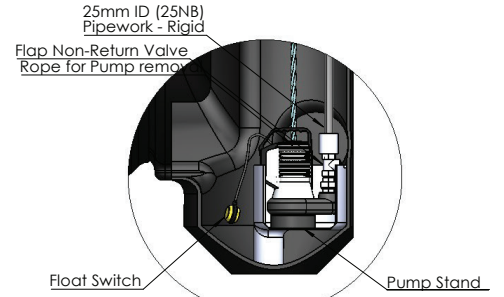

Detail Pump

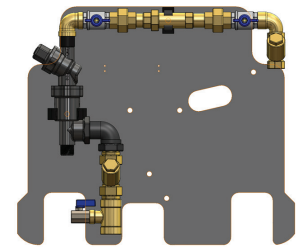

Connection Schematic in Cabinet

## Pump Setups

### RainWorx® underground tank with above ground pump multistage use (Variable Drive)

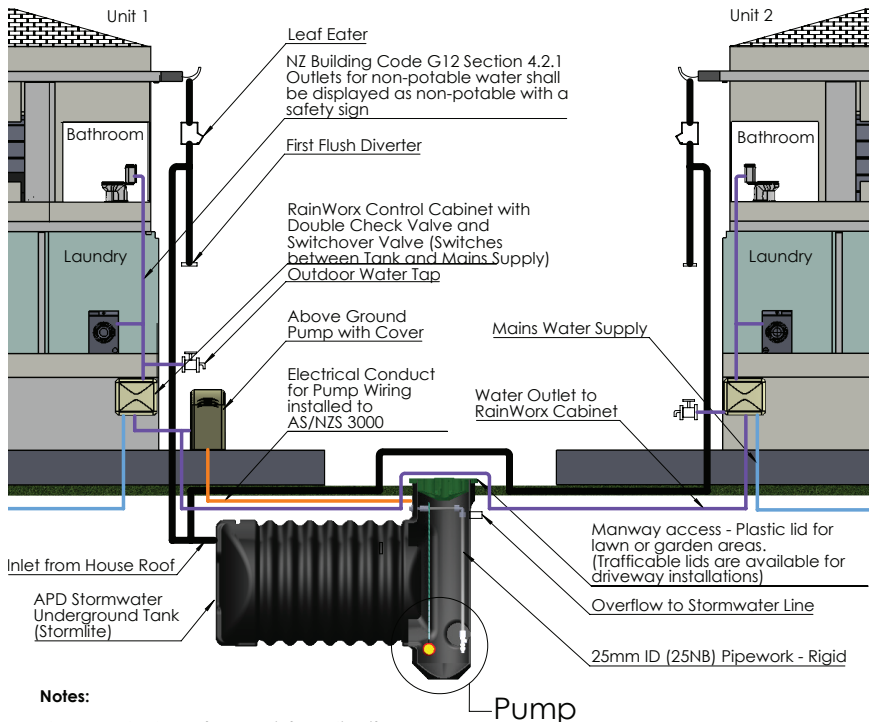

**Notes:**

Please contact APD for more information if more than two units/houses to be connected

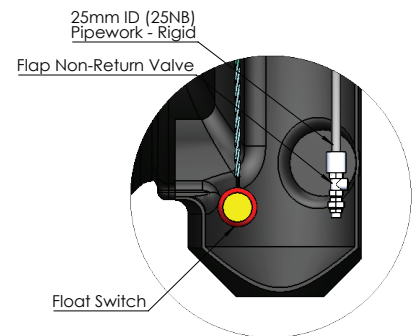

Detail Pump

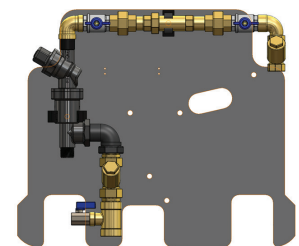

Connection Schematic in Cabinet

## Pump Setups

### RainWorx® underground tank with submersible pump garden use only

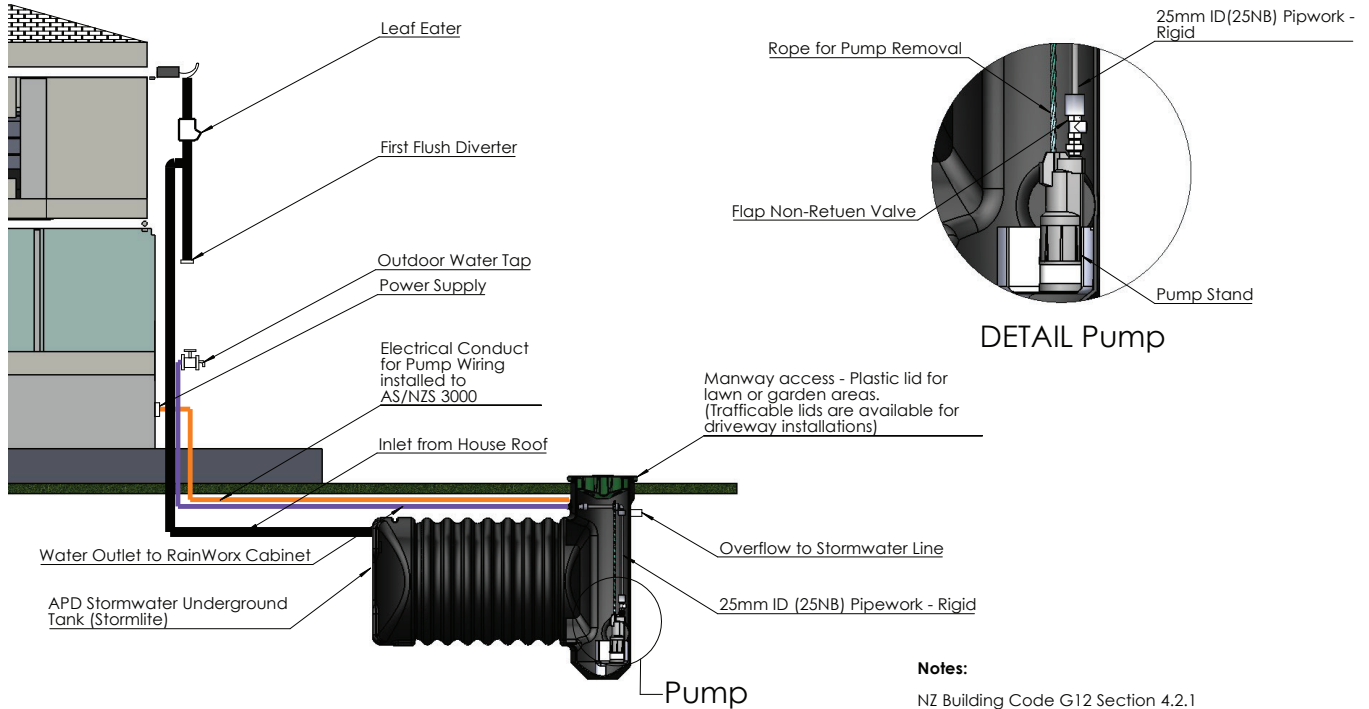

## Pump Setups

### RainWorx® above ground tank with above ground pump garden use only

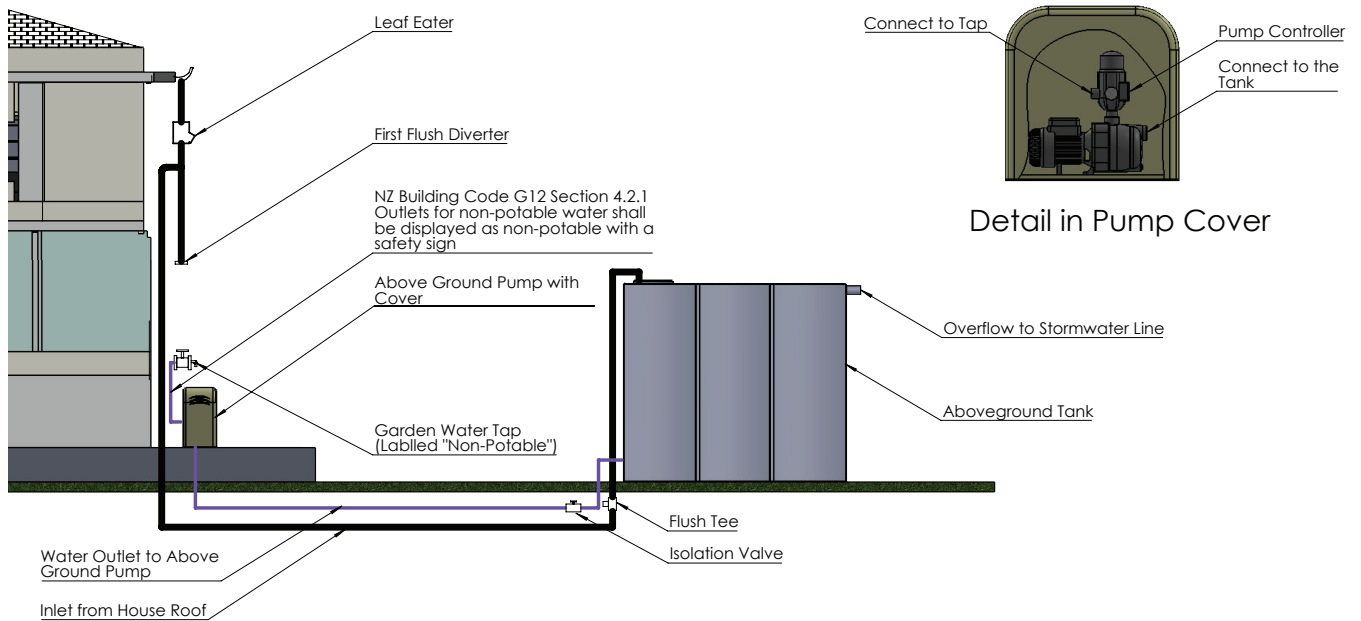



Doing Good From The Ground Up

## Troubleshooting

### Mains water flow not available or low when pump is switched off or not operating

- Check mains water isolation valves are open.
- Undo the cap on the mains water strainer and check for blockages (turn off mains water first).

### Pump not working or low flow

- Check there is power to the Pump Controller or Rainbank.
- Check you have the correct sized pipework installed throughout the installation as per part 3 note 4 of this manual.
- Check there is sufficient water in tank for the pump float switch to be in the up position.
- Press pump reset (Whites) or pump override (Davey).
- Check the tank water strainer inside the cabinet for any blockages.

### Pump running continuously or intermittently when water not being used

- Check for any leaks in the plumbing.
- Check the power from the pump is plugged into the Pump Controller or Rainbank and not directly into the power point.
- Manual override button (Davey) or pump reset button (Whites) is blocked. Please press it several times.

### Pump is pumping discoloured/dirty water

- Check the water inside the tank for debris or discoloration, if necessary, have the tank water emptied and the tank cleaned.
- Check the roof, gutters or any other area where the water is being collected for possible contamination.
- We recommend the use of first flush diverters and/or leaf guards to minimise the ingress of organic matter.

### Problems with Davey system

- <https://www.daveywater.com/nz/product/cabinet-mounted-rainbank>
- Go to Rainbank installation and operating guide

### Problems with Whites system

- Problems with pump change over system
- The water pump supplies harvested rainwater via the RainWorx® system to the non-potable taps provided there is water in the storage tank. This system works automatically. A pump controller senses the pressure drop when a tap is opened turning the pump on to deliver water.
- When the water level in the tank is too low for the pump to operate, a mechanical change over device switches from pumped water to mains supply. This may be noticeable as the mains supply is limited to 1.8 bar pressure, whereas the pump supplied water is at 2 bar pressure or higher.
- To test if the system is operating correctly, check the storage tank has water in it and open a tap that is connected to the rain harvested supply. Water should be delivered. To confirm it is the pumped water being delivered, turn off the main supply at the street isolating valve – REMEMBER TO TURN YOUR SUPPLY BACK ON once your check is completed!

## Troubleshooting Continued

### Problems with Whites system

- Next, turn off the power supply to the RainWorx® cabinet. Water should continue to flow from the tap. This is mains water being supplied. Note, the pressure may be less than when the pump is operating.
- If you find when testing the system, there is no supply from the pump when the mains supply has been operated it's possible that the incoming mains pressure from your street supply is higher than expected, and therefore an adjustment may need to be made to the changeover device pressure. So if the pump is not automatically starting, then you will need to contact APD.

### It has recently rained but my system is not using water from the storage tank.

- During dry periods when the water tank is empty, the pump controller stops the pump from running when there is no water available. Every 24 hours, the pump controller starts the pump for a few seconds to test if water is available. If the tanks have filled between these 24-hour tests, the pump will not deliver water until the 24-hour interval between tests has expired. To reset the pump controller and start the pump, turn the power off to the RainWork cabinet for 30 seconds and back on. This will cause the pump controller to reset and the system should then deliver water from the tank.



**Do not attempt to open the Whites Pump Controller or Davey Rainbank as there are exposed LIVE 230/240V electrical connections inside.**

## Maintenance Instructions - Every 12 Months



**There are no householder serviceable items in the system. Only use an authorised APD service agent to work on your RainWorx® system.**

### To be carried out by a qualified service person:

- Clean any dirt or debris from the RainWorx® cabinet components.
- Ensure water is flowing freely through the RainWorx® cabinet components.
- Clean both strainers inside RainWorx® cabinet.
- Check inside water tank for debris and clean out if necessary.
- Check and clean leaf eaters/first flusher diverters if installed on spouting.
- Check and clean the mesh under the hatch in the top of the StormSlim tank. It can be removed and cleaned with a hose.



Doing Good From The Ground Up

## Warranties & Assurances

### APD RainWorx® pumps and controllers servicing and warranty

The APD RainWorx® standard system utilises pumps and controllers from both Whites International and Davey Water Products. Faults or warranties are covered by the supplier directly. For any concerns with your pump or controller please contact the relevant supplier. The warranties offered are considered back to base warranties only. Charges may be incurred for replacement/removal labour and any installation issues identified are not covered by either APD or the pump supplier.

The RainWorx® cabinet and componentry is covered under warranty for 2 years as outlined below.

Whites Rainsaver Version: Bianco B42A Pump has a 2-year warranty when used in conjunction with the Rainsaver unit.

Davey Rainbank Version: Davey D42A/B Pump has a 2-year warranty when used in conjunction with the Davey Rainbank unit.

**Failure to ensure correct pipe sizing for entire system will void all warranties and may incur service or repair charges.**

**If you can't resolve your issue with the troubleshooting guide above, please phone APD on 09 263 7741.**

#### RainWorx® Davey setup

Pump D42A/B-3  
Rainsaver RB2/S-2  
Davey Water Products  
Ph 0800 654 333  
7 Rockridge Road  
Penrose  
Auckland 1061

#### Whites International setup

Pump Bianco BIA-B42A  
Whites Adjustable controller WHI-SK13BA  
Rainsaver 804683  
White International  
Ph 0800 509 506  
15G Kerwyn Ave  
East Tamaki  
Auckland 2013

