

StormSlim®

DETENTION & RETENTION SOLUTIONS

The Compact Home System.

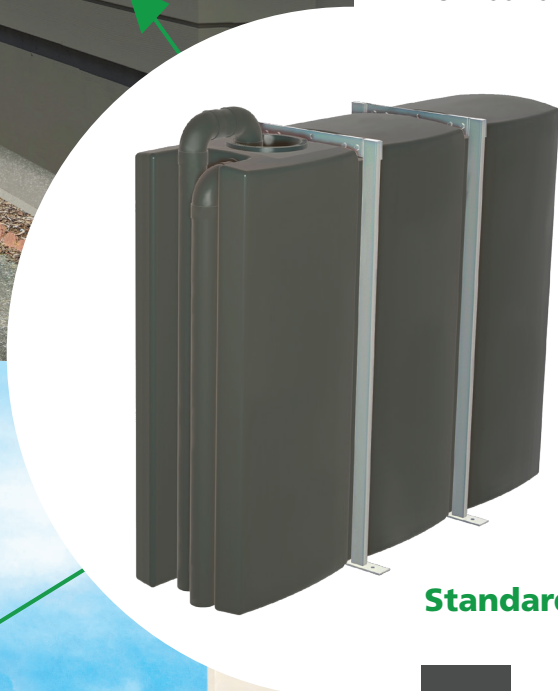

The APD StormSlim® System is the Perfect Above Ground Tank Option for Compact Spaces!



StormSlim® is an innovative stormwater detention and retention system designed to manage your rainwater and stormwater when outdoor space is at a premium.

StormSlim®'s compact dimensions and height means you can maximise the use of the outdoor space available without the visual impact of unsightly tanks. Designed to effortlessly and elegantly fit in with the exterior of your home whether retrofitting or a new build.

Now Available in 24 COLOURSTEEL® Colours

Standard Colours



Grey Friars



Ironsand



Ebony/Black



Sandstone Grey



Karaka

Standard lead times and charges apply. Please contact us to find out more.

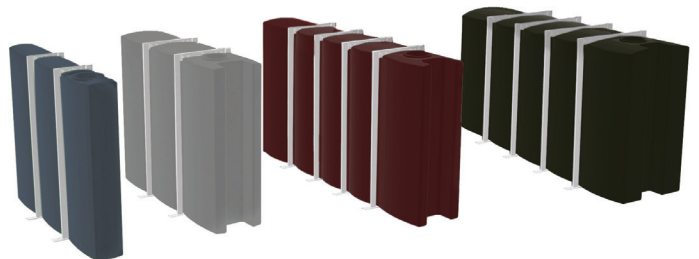

Doing Good From The Ground Up

For more information call 0800 263 774
www.apd.co.nz

Designed to Suit Your Home

APD's StormSlim® tanks come in a variety of designer colours to perfectly match or complement your home. Whether you choose to match the tank colour to your house or fence, or opt for a bright pop of colour as a design feature, there's a colour option to suit.

Concealed and Out of Sight

Prefer to conceal your tank? APD's StormSlim® tanks can be housed in various cladding and fencing options by simply fixing framework to the galvanised support frames. Ask us about our optional framing kit to allow concealing the ends of the tank. The 2000, 3000, and 5000 litre StormSlim® tanks also come with a recessed end to help conceal the pipework.

Features

- New modular sizing minimises footprint.
- Multiple tank sizes to suit any design, including 1000, 2000, 3000, and 5000 litre options.
- PS1 for seismic restraints and engineered concrete slabs.
- All tanks are 1800mm high to match standard fence requirements.
- Manufactured to AS/NZS 4766:2020 from water tank grade PE material suitable for potable water.
- Designed and made in New Zealand for local conditions.
- Compatible with APD RainWorx® systems and pumps.
- Engineered to meet the seismic requirements of Zone 1, 2 and 3, Wind Zone NZ1/NZ2, and Soils A-D.
- Comes with 300mm tank screen, lid & 2 x Wallace seals.

Tank Dimensions

Tank Size	Height (mm)	Width (mm)	Length (mm)	Slab Width (mm)	Slab Depth (mm)	Slab Length (mm)
1000 Litre	1800	360	2285	790	150	2400
2000 Litre	1800	640	2285	1073	200	2400
3000 Litre	1800	640	3400	1073	200	3500
5000 Litre	1800	1000	3400	1433	200	3500

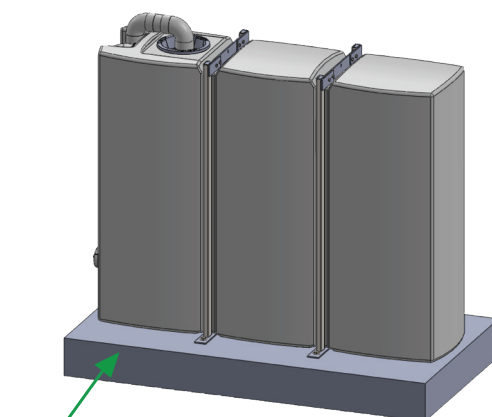

Seismic base slab

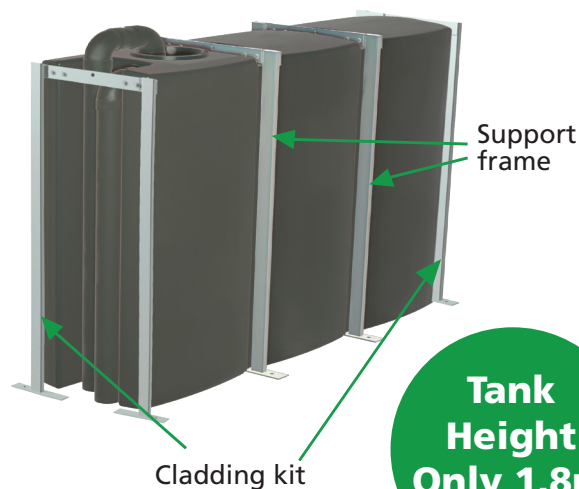

Tank Height Only 1.8m

Benefits

- **Customisable cladding:** Seamlessly integrate your StormSlim® tank with your home's exterior for a cohesive look.
- **All-in-one solution:** Comes pre-plumbed with all necessary pipework for a hassle-free installation.
- **Colour-matched design:** Coordinate your tank and fence with your home's existing joinery, roof, or cladding colours.
- **Effortless compliance:** Meets the 1800mm height requirement without needing additional consent.



Doing Good From The Ground Up

For more information call 0800 263 774
www.apd.co.nz